



Accelerating solutions for highway safety, renewal, reliability, and capacity

SHRP 2 Safety
Naturalistic Driving Study

PROLOGUE Workshop
February 18, 2010

TRANSPORTATION RESEARCH BOARD
OF THE NATIONAL ACADEMIES

SHRP 2

- Authorized by Congress in 2005 highway legislation
- \$170 million, 7 years (2006-2013)
- Administered by TRB under MOU with FHWA and AASHTO; coop. agreement with FHWA
- Four Research Focus Areas:
 - Safety
 - Renewal
 - Reliability
 - Capacity
- Neil Hawks, Director

SHRP 2 Governance

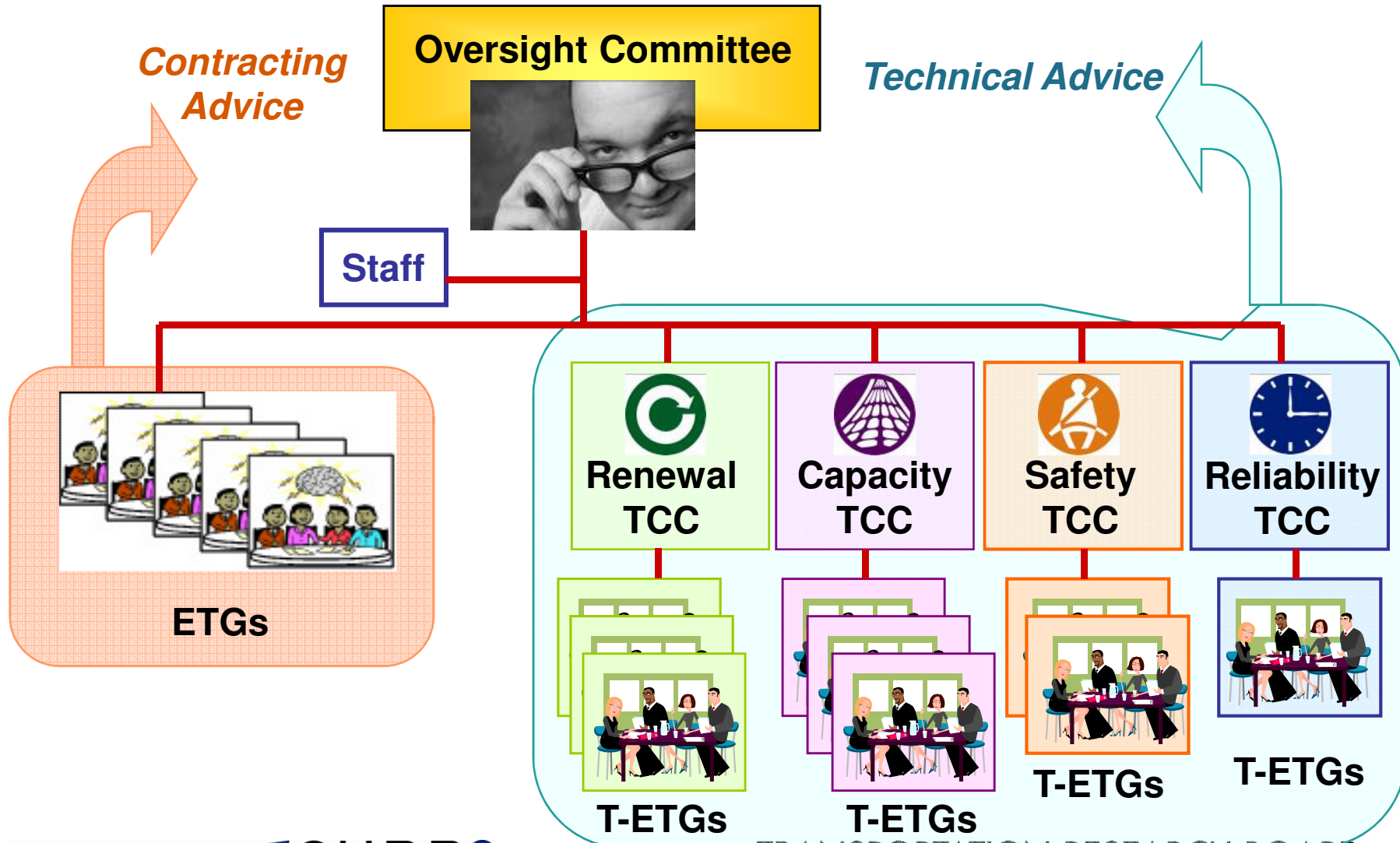

Safety Contracts

Program Coordination



Project Management



Research

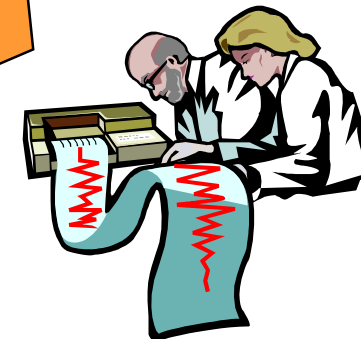

Technical Advice



The Highway Safety Problem

- 40,000 deaths annually
- More than 2 million injuries
- More than \$200 billion/year economic costs
- Top cause of death for ages 5-34
- Potential negative impact of demographic changes (such as aging population) and technological developments (technologies installed or brought into the vehicle)

SHRP 2 Safety Research Program

GOAL

Greatly increased knowledge of *driver behavior*

- § How the driver interacts with and adapts to the vehicle, roadway characteristics, traffic environment, traffic controls, weather, etc.
- § Differences in *crash risk* associated with these interactions
- § Proposed countermeasures based on the findings



Why a Naturalistic Driving Study?

- Collect more and better data:
 - Objective pre-crash data
 - More accurate crash data
 - Near crash/incident data
 - “Exposure” (ordinary driving) data
- Determine relative crash risk for different factors
- Develop crash surrogates

Safety Program Status Transition

Projects Ending 2009 (7)

- S01: Development of Analysis Methods (4 projects)
- S02: Analysis Integration/Workplan, University of Iowa
- S03: Roadway Measurement System Evaluation (Rodeo), ARA
- S05: Naturalistic Driving Study Design, VTTI

Projects Ending 2010 (1)

- S09: Site-Based Video System Development, UMTRI

New Projects (9)

- S12A: Data Acquisition System (DAS) Procurement
- S06: Technical Coordination and Quality Control
- S07: Naturalistic Driving Study Site Contractors (6 projects)
- S04A: Roadway GIS Database and S04B Quality Control

RFP 2010

- S04B: Mobile Roadway Data Collection
- S08: Naturalistic Driving Study Analysis (multiple projects)

SHRP 2 Safety Projects Timeline

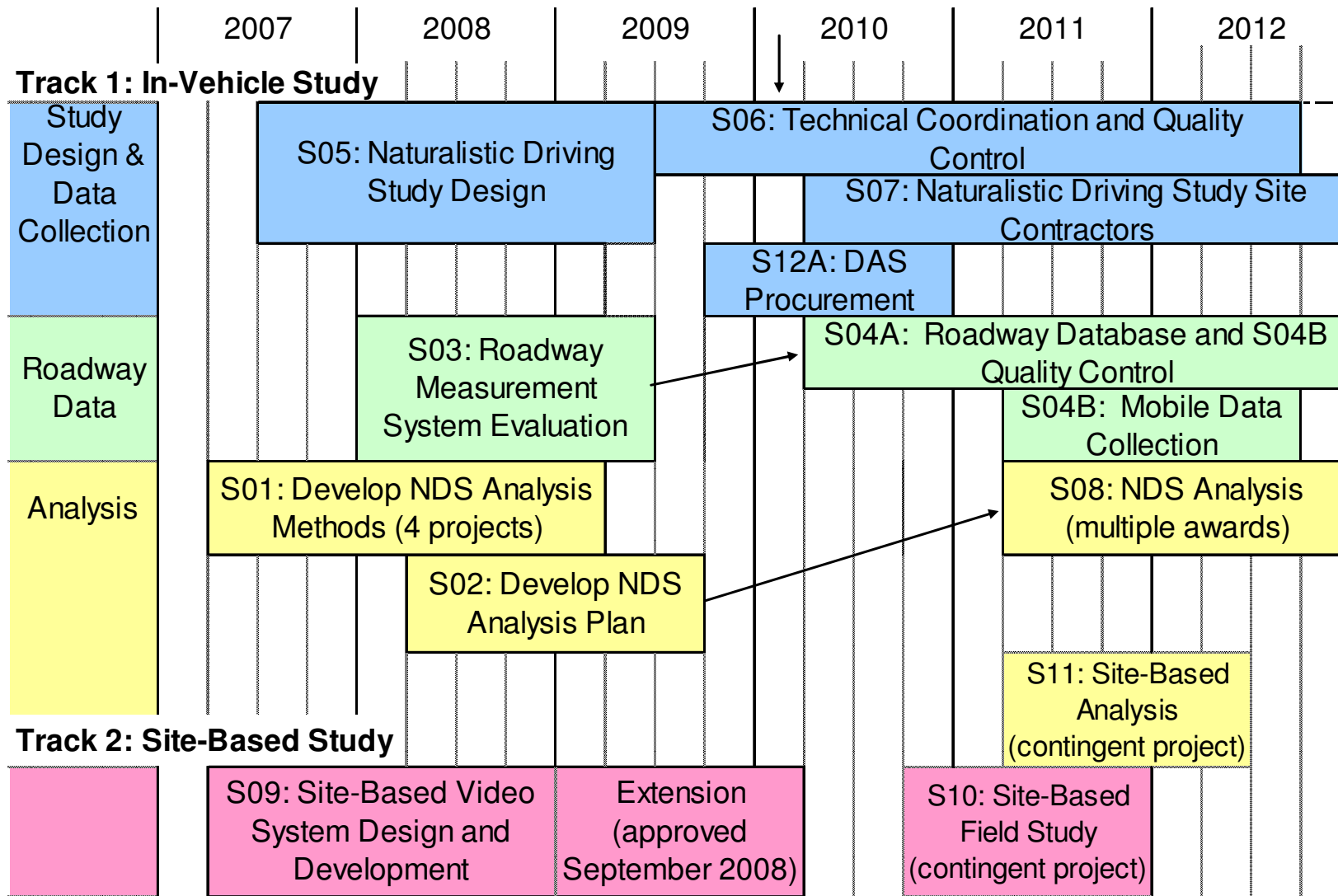

Revised February 2010

Naturalistic Driving Study

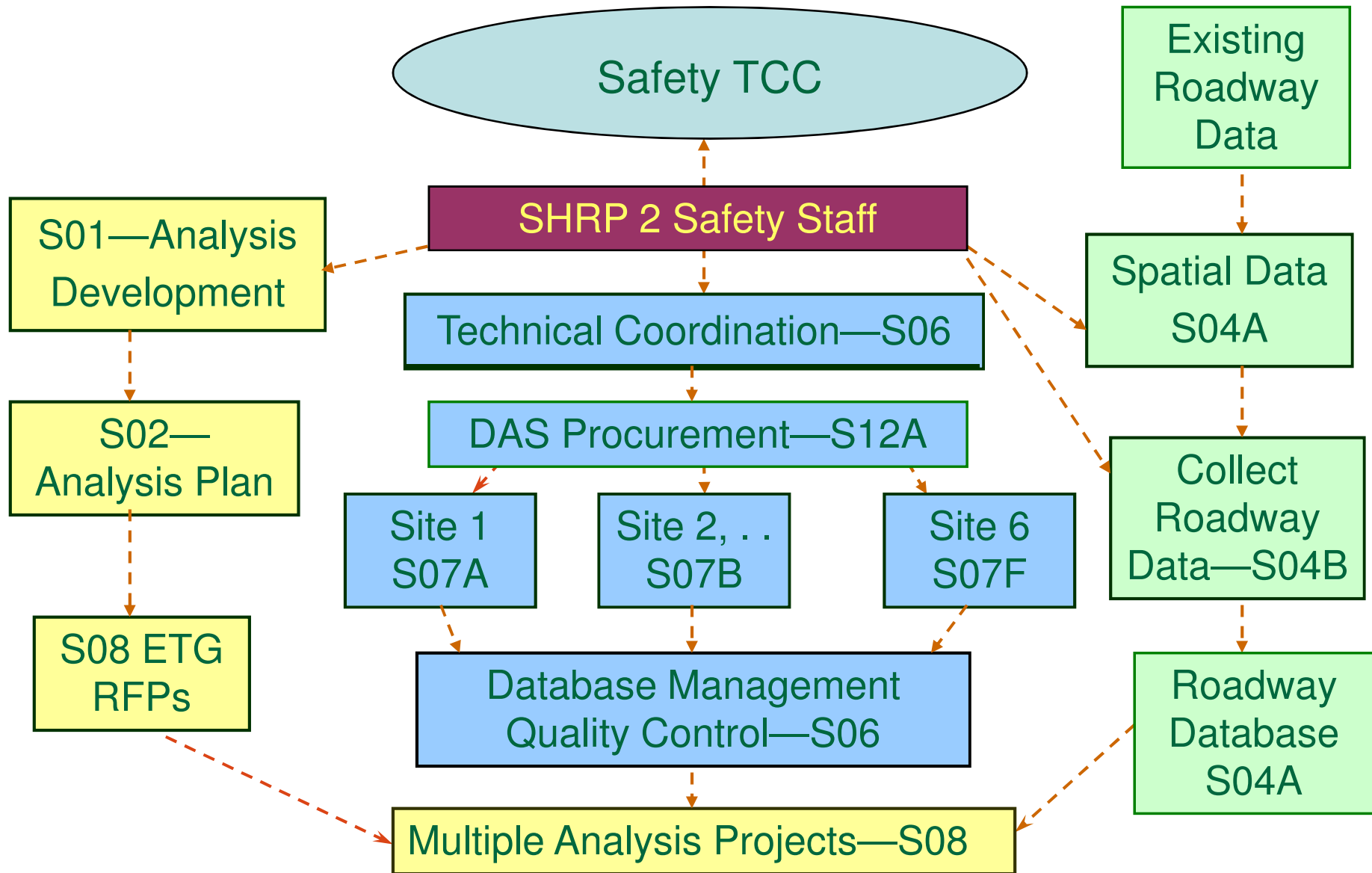

SHRP 2 NDS

- 1950 instrumentation packages 2 years: 3900 data years
- 3100 participants: some 1-year, some 2-year
- Recruitment:
 - Primary: random listed sample (central)
 - Secondary: targeted (site)
- Passenger cars, vans, SUVs, pick ups
- 6 sites:
 - Bloomington, IN-- Erie County, NY
 - Central PA -- Raleigh-Durham, NC
 - Tampa Bay, FL -- Seattle, WA

SHRP 2 Safety Focus Area Naturalistic Driving (Project S07) Data Collection Sites

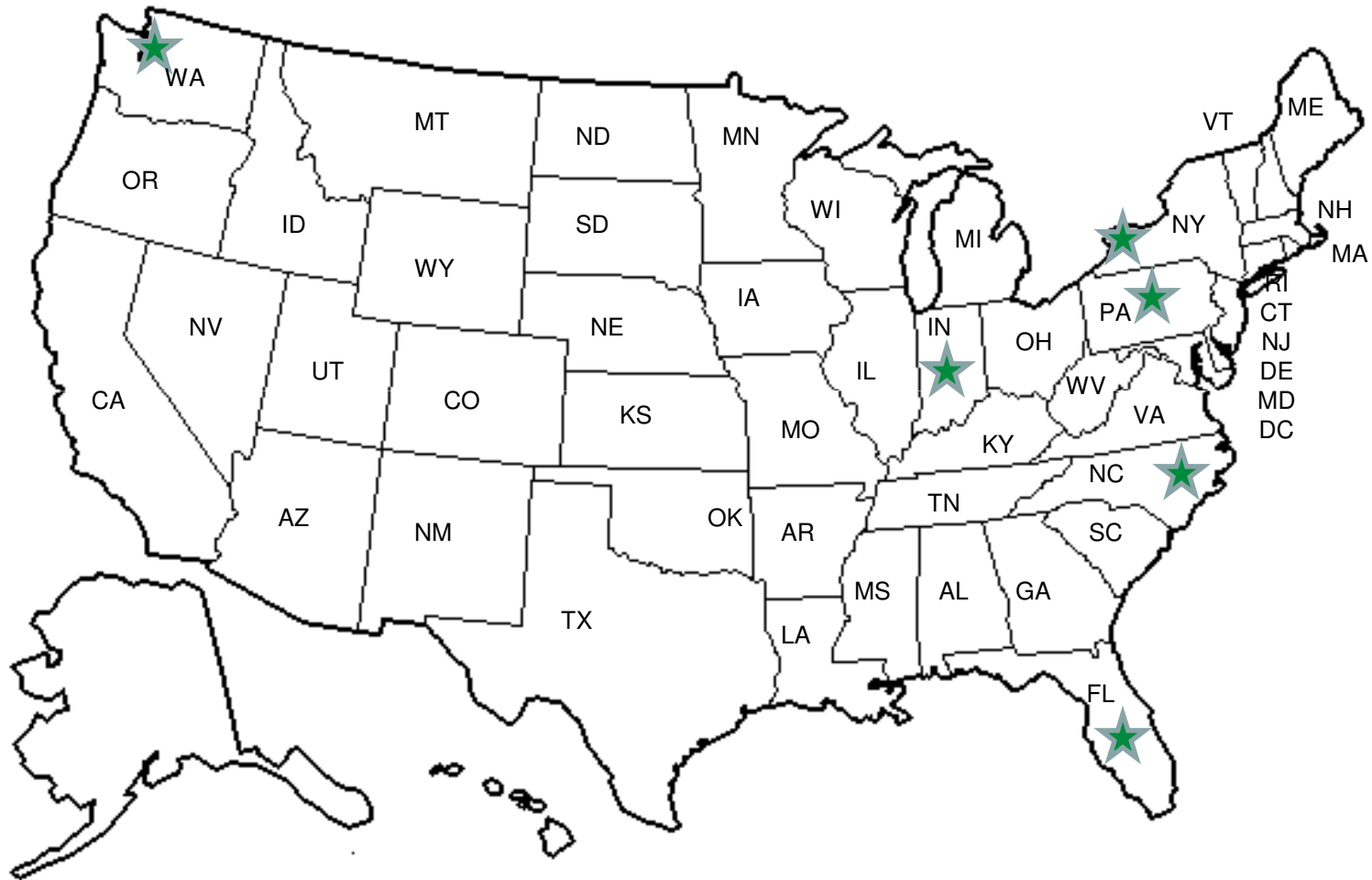

Participant Sample Design

Gender and Age Range	Age Range Description	One Year	Two Years	DAS units	Primary Participants	Data-Years
M 16-17	Minor Teen	72	28	100	172	200
M 18-20	Adult Teen	72	28	100	172	200
M 21-25	Young Adult	72	28	100	172	200
M 26-35	Adult	72	28	100	172	200
M 36-50	Middle Adult	72	28	100	172	200
M 51-65	Mature Adult	72	28	100	172	200
M 66-75	Young Old Driver	72	28	100	172	200
M 76+	Older Older Driver	72	28	100	172	200
F 16-17	Minor Teen	72	28	100	172	200
F 18-20	Adult Teen	72	28	100	172	200
F 21-25	Young Adult	72	28	100	172	200
F 26-35	Adult	72	28	100	172	200
F 36-50	Middle Adult	72	28	100	172	200
F 51-65	Mature Adult	72	28	100	172	200
F 66-75	Young Old Driver	72	28	100	172	200
F 76+	Older Older Driver	72	28	100	172	200
Any	Adv Vehicle Tech	0	350	350	350	700
Totals:		1,152	798	1,950	3,102	3,900

DAS System Components

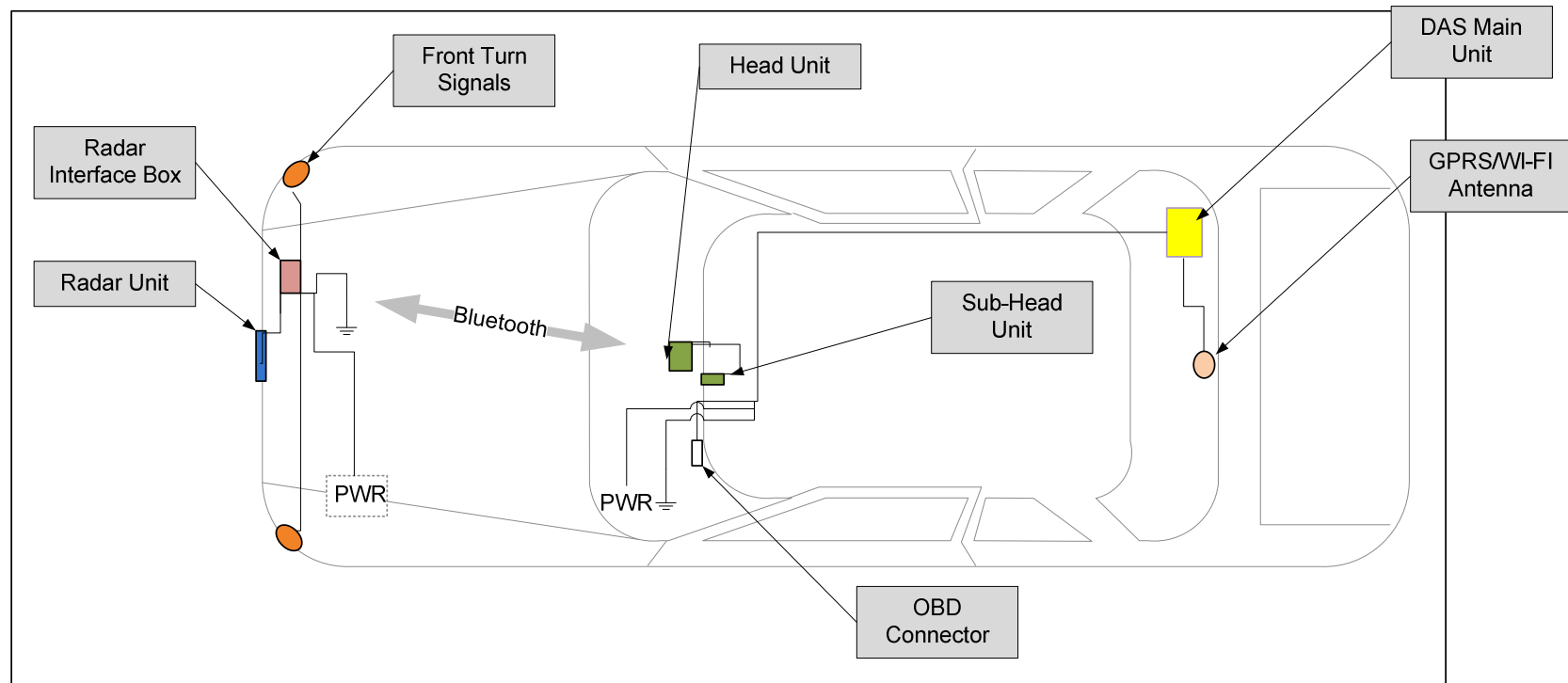

Head Unit with Cameras

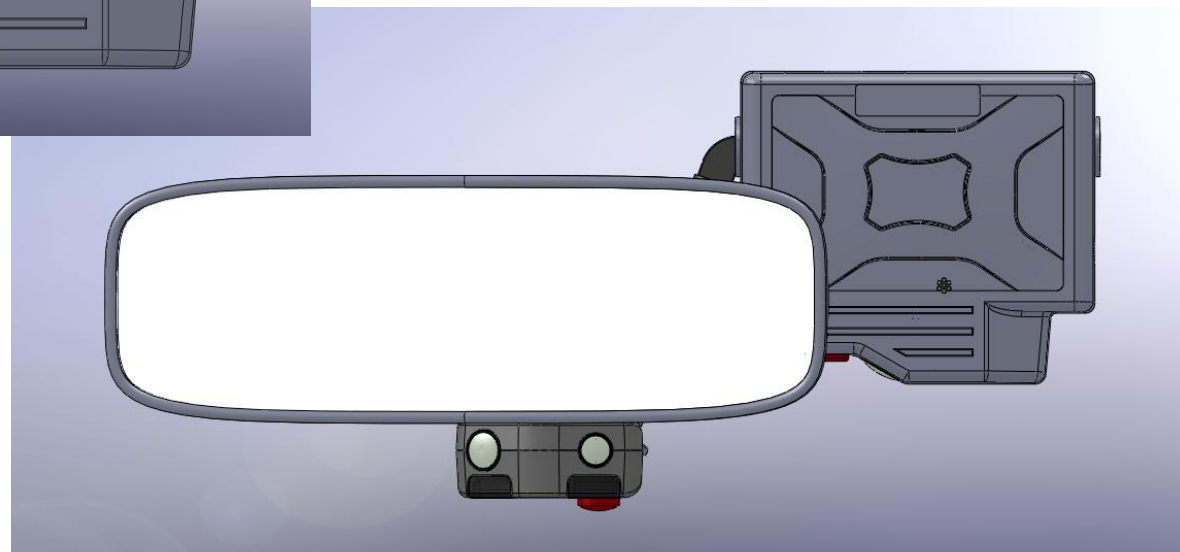
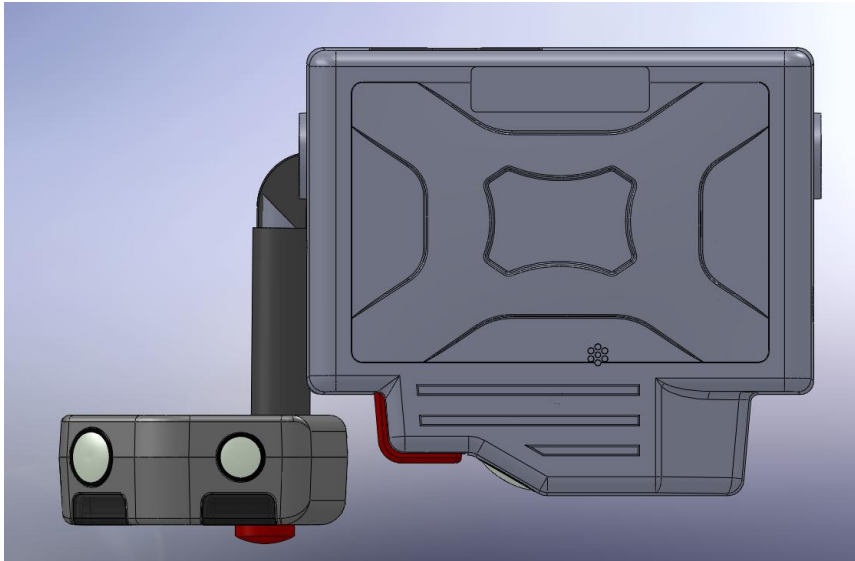

Camera Image Samples

Forward View - color

- 15 Hz continuous video
- 640x320 pixels



**Driver Face –
Rotated for max
pixel efficiency**

Right-Rear View

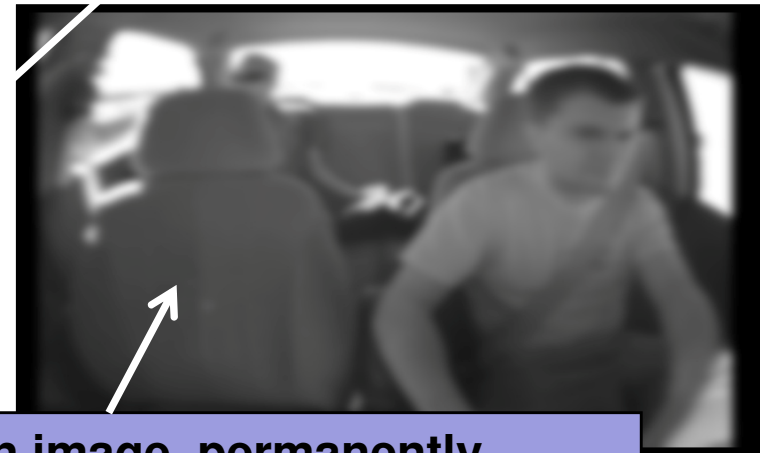

**Center stack –
Pedal Interactions**

**Periodic still cabin image, permanently
blurred for passenger anonymity**

DAS Acquisition Stages

- § RFP released—October 2009
- § Bids received—December 2009
- § Initial contracts (3) for 15 prototypes—January 2010
- § Prototypes testing and evaluation—April 2010
- § Pre-production contract for 100 units—June 2010
- § Acceptance testing and evaluation—August 2010
- § Full production delivery beginning—September 2010
- § Production goal: 700 units per month

Data Summary

Sources of data being collected:

1. From instrumented vehicles: continuous recording of video and sensor/parametric data
2. Driver assessment tests for primary drivers
3. Detailed crash investigations for selected crashes
4. Roadway/roadside characteristics and features from mobile data collection vans and external sources

800 TB of video + 100 TB of vehicle sensor data +
roadway data = ~1 petabyte of data

Some Elements of Participant Protection

- DHHS policy for the Protection of Human Subjects (45 CFR 46)
- Multiple Institutional Review Boards:
 - 6 site contractor IRBs
 - Virginia Tech IRB
 - NAS IRB
- NIH Certificate of Confidentiality (VT “lead”)
- Elements of consent process:
 - Consent Forms
 - Web site
 - Video

Ken Campbell
SHRP 2 Chief Program Officer
Transportation Research Board
(202) 536-5187
kcampbell@nas.edu
<http://www.trb.org/shrp2/>